

QJ16

Spring Loaded Potentiometer

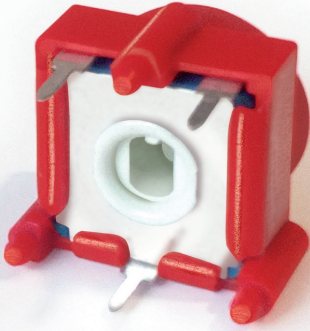

QJ16

ACP Q16 series expands its range with the launching of the new spring loaded potentiometer version called QJ16.

Keeping the same dimensions and layout of the Q16, the functionality is completely different. When the operator turns the knob CW or CCW from the central rest position, a spring mechanism fitted into the component provides an opposite torque. When releasing the knob, the spring returns the potentiometer to the central rest position.

Electrically, the potentiometer is a standard 245° linear taper with a 5% absolute linearity. The mechanical rest position corresponds to the physical middle position, hence to the central value of the output signal. Starting from there, the output value varies along the linear curve until reaching the corresponding end stop.

An alternative output signal to the above is an SPDT (Single Pole, Double Throw) configuration, with “on” positions at both mechanical end stops and “off” position in the central rest position. Mechanical angle option available is $\pm 45^\circ$.

Application:

This Spring Loaded potentiometer is the ideal alternative to a tact switch or incremental encoder to increase or decrease the value of a certain parameter.

QJ16 HOW TO ORDER

EXAMPLE: QJ16RV15 10KA3030 LV10

Standard features

Series	Rotor	Model	Packaging	Ohm value	Taper	Tolerance	Life	Mechanical Angle	Terminals	Flammability	Position
1	2	3	4	5	6	7	8	9	10	11	12
QJ16	R	V15		10K	A	3030	LV10	±45°			

Standard configuration:

QJ16

Dimensions:	16x15mm
Protection:	IP 54. On request: Self extinguishable, to meet UL 94 V0
Core potentiometer:	CA14 // RS14
Packaging:	Bulk A
Wiper position:	Middle position
Terminals:	Straight
Marking:	Resistive value marked on housing. Others on request.

1 - Series

■ QJ16

2 - Rotors

R Standard. (Others under study).

3 - Model and pitch

V15 Standard. VSMD under study.

4 - Packaging

Bulk (blank)...⁽¹⁾

⁽¹⁾ Products supplied bulk packed in bags, unless otherwise specified.

5 - Resistive value

100Ω	200Ω	220Ω	250Ω	470Ω	500Ω	1KΩ	10KΩ standard...	5MΩ
100	200	220	250	470	500	1K	10K	5M

6 - Taper

Lin - Linear A

Others under study. Code will be assigned case by case.

7 - Tolerance

100Ω ≤ Rn ≤ 100KΩ:	100KΩ ≤ Rn ≤ 1MΩ:	1MΩ ≤ Rn ≤ 5MΩ:
±30%	±30%	+50%, -30%
3030	3030	5030

Special tolerances under request. Please check availability.

8 - Operating Life (Turns)

Standard (10.000 cycles)	LV10
Long life: LV + number of cycles. (please inquire availability).	LVXXX: ex: LV20

9 - Mechanical Angle

Standard ±45°	(leave blank)
Other configurations under study	

10 - Terminals

By default, terminals are always straight	(leave blank)
SNAP IN P	SNP
Steel Terminals	SH

11 - Flammability

Standard: Non self extinguishable.	(leave blank)
All housings and rotors self extinguishable according to UL 94 V0.	V0
Only QJ16 housing and rotor self extinguishable V0	Q-V0

12 - Delivery position

Standard, middle position	(leave blank)
---------------------------	---------------

Special marking

Special marking	GRE
-----------------	-----

Rotor

R is the standard rotor for QJ16. Other options can be made under study.

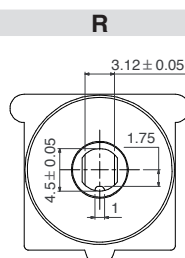

This drawing shows the rotor at 50% position, which is the standard delivery position.

Models

V15 is the standard model.

V15

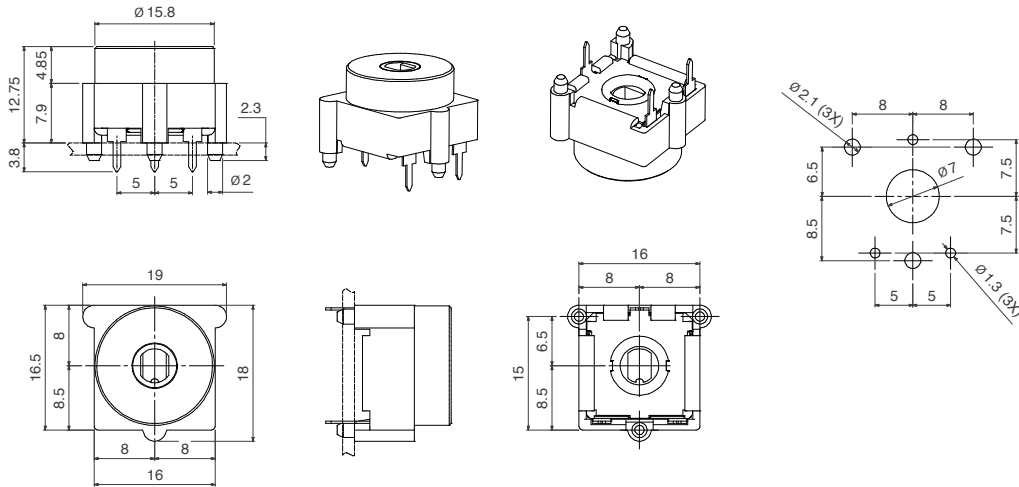

Tapers

The core potentiometer is a standard 245° linear taper with a 5% absolute linearity. The mechanical rest position corresponds to the physical middle position, hence to the central value of the output signal. Starting from there, the output value varies along the linear curve until reaching the corresponding end stop.

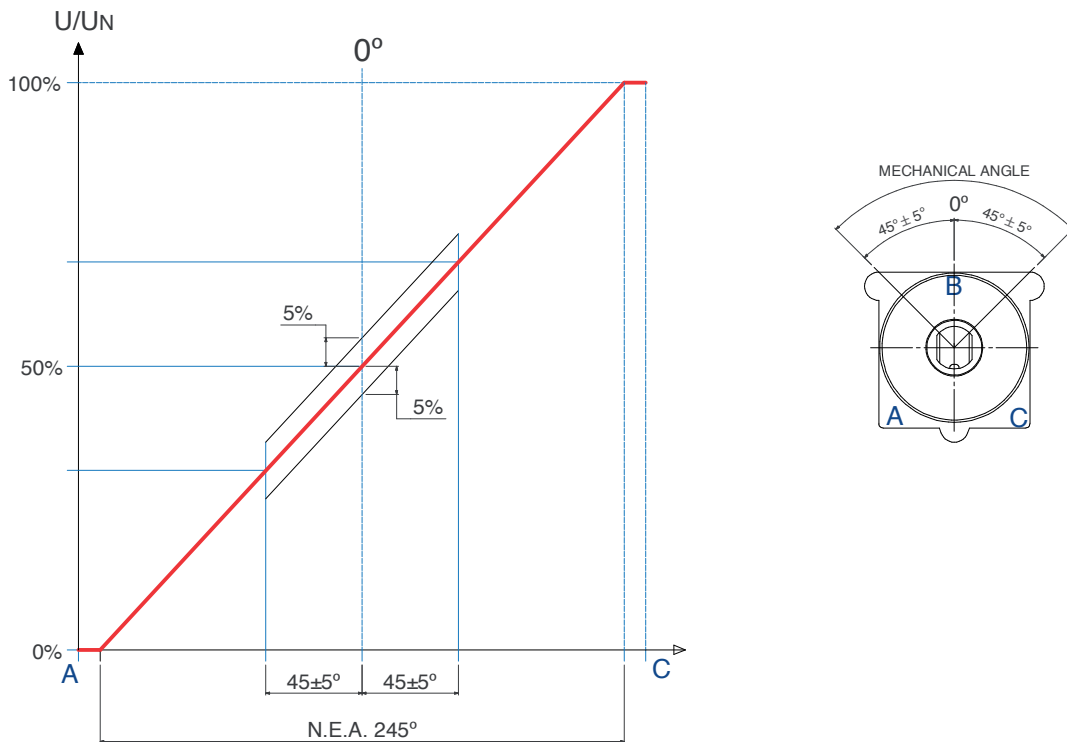

An alternative output signal to the above is an SPDT* configuration, with “on” positions at both mechanical end stops and “off” position in the central rest position. Mechanical angle option available: $\pm 45^\circ$

*Single pole, double throw. A simple break-before-make changeover switch: C (COM, Common) is connected either to L1 or to L2

Delivery Position

The QJ16 is delivered with the wiper on middle position.

Shafts

Shafts are sold separately. They can be inserted from either top or below side.
Please consult ACP for studying special designs.
Rotor inner dimensions shown for customer's own shaft design.

Rotor inner dimensions

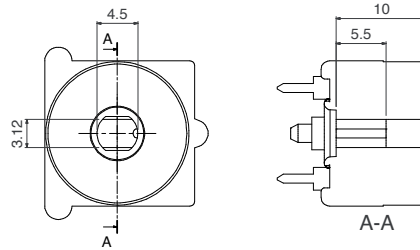

This drawing shows the rotor at 50% position, which is the standard delivery position

14301

14315

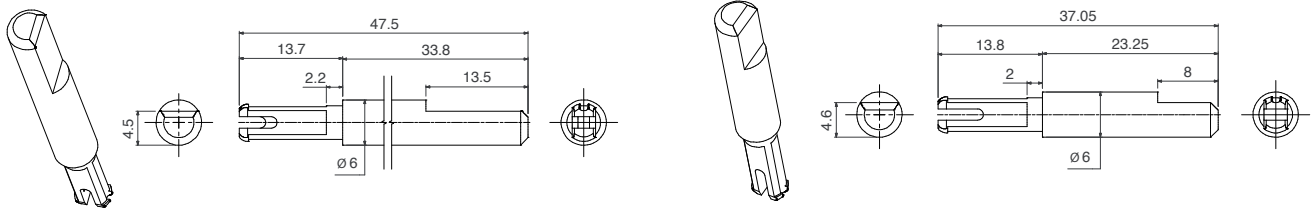

Packaging

Bulk packaging:

Pieces per box (250 x 150 x 70)

QJ16 model

200

Electrical Specifications

Range of resistance values*	Standard value is 10k
Tolerance	±30%
Variation laws	Lin (A). Other tapers available on request
CRV - Contact Resistance Variation (dynamic)	Lin (A) Electrical Angle $245^{\circ} \pm 20^{\circ} \leq 3\%R_n$. Other tapers, please inquire
CRV - Contact Resistance Variation (static)	Lin (A) Electrical Angle $245^{\circ} \pm 20^{\circ} \leq 5\%R_n$. Other tapers, please inquire
Maximum power dissipation**	at 50°C, 0.15W
Maximum voltage	250VDC
Operating temperature	-25°C ... +70°C (Other under request)
Electrical angle	$245^{\circ} \pm 20^{\circ}$
Linearity	5%
Temperature coefficient	+200/ -300 ppm

Mechanical Specifications

Resistive element	Carbon technology
Angle of rotation (mechanical)	$\pm 45^{\circ} \pm 5^{\circ}$
Wiper standard delivery position	Neutral position $\pm 5^{\circ}$
Max. stop torque	50Ncm
Max. push/pull on rotor	50N
Wiper torque*	0,5-3,5Ncm
Mechanical life	10.000 cycles.

* Out of range ohm values and tolerances are available on request, please, inquire.

** Dissipation of special tapers will vary, please, inquire.

Test results

The following typical test results (with 95% confidence) are given at $23^{\circ}\text{C} \pm 2^{\circ}\text{C}$ and $50\% \pm 25\% \text{RH}$.

	Test conditions	Typical variation of R_n	Linearity after test
Damp heat	500 h. at 40°C and 95% RH	±20%	7%
Thermal cycles	16 h at 85°C , plus 2 h at -25°C	±20%	7%
Load life	1.000 h. at 50°C	±20%	7%
Mechanical life	10.000 cycles at 10 c.p.m. and at $23^{\circ}\text{C} \pm 2^{\circ}\text{C}$	±20%	7%
Storage (3 years)	3 years at $23^{\circ}\text{C} \pm 2^{\circ}\text{C}$	±3%	7%